



The Economics Of Air Drying

Presented at the
37th National Conference on Fluid Power
Chicago, Illinois, October 18 – 21, 1981

Updated September, 1998

Charles Henderson, Vice President
Henderson Engineering Co., Inc.

WET COMPRESSED AIR

Compressed air must be dried. This is an undeniable statement of fact. Today's modern industry can no longer tolerate the problems of wet, dirty compressed air. Wet air causes rust, pitting, blockages, and freeze-ups, with resultant component failure and product rejection. Wet air is a major contributor of downtime, causing millions of dollars of lost production.

The cost of wet air varies with each and every application. However, the cost of wet air is always many times greater than the cost of a dryer. Compressed air dryers pay for themselves, many times over, by increasing production, reducing downtime and adding to your bottom line. The tough question you have to answer is which type of dryer is the best choice for your application.

There are three basic types of compressed air dryers: deliquescent, refrigerant, and regenerative. The dryer you should select is determined by answering the question, "How dry does my air need to be?" The Instrument Society of America has a standard for instrument air that can be applied to many non-instrument applications as well. The standard states "Air shall be dried to a dewpoint 10°C (18°F) below the lowest ambient temperature the air will encounter. In no event shall the dewpoint exceed 2°C (35°F)." Many companies have adopted this standard and even vary the dewpoint requirements with the season.

There is no real advantage to over-specifying a dryer, because as long as the water in your compressed air

lines remains in a vapor form, it will not harm your compressed air machinery. Only when water reaches its dewpoint and condenses from a vapor into a liquid do you have problems. Generally speaking, over-specifying the required dewpoint doesn't provide tangible benefits. On the other hand, given the high cost of wet air, making sure you buy a dryer that completely eliminates all wet air problems is a pretty good idea.

The reason we specify a dewpoint 10°C (18°F) below the lowest ambient is to account for adiabatic expansion, the cooling that occurs when air is rapidly expanded to atmospheric pressure. A good example of this is a spray gun. When the air goes shooting out the spray gun, it cools; if the air has not been adequately dried, it will reach its dewpoint and water droplets will mix in with the paint, ruining the paint job.

If your air is used indoors for general shop air and does not encounter any special conditions, the dewpoint from a deliquescent or refrigerant dryer should be adequate. Outdoor lines, instruments, and special applications require the dewpoint from a regenerative dryer. See Table 1.

Dryer Type	Pressure Dewpoint
Deliquescent	Varies; will be 20°F-40°F lower than the inlet air temperature
Refrigerant	+35°F at best; usually higher
Regenerative	Either -40°F or -100°F

Table 1

In order to properly size a dryer, you need to know three things: (1) maximum amount of air to be dried in SCFM, (2) minimum inlet air pressure in PSIG, and (3) maximum inlet air temperature in °F.

The reason you need these numbers is quite simple. First, you need to know specifically how much air you want dried. If you want to dry the outlet of a single compressor, size the dryer for the maximum output of that compressor. For multiple compressors, add up the total flow. All dryers are designed to operate from 0 to 100% of design flow, so we need only be concerned with the maximum air flow.

The pressure affects several things; the air's capacity to hold moisture varies with the pressure, as does its velocity. Most dryer manufacturers design their dryers with a standard rating of 100 PSIG. If your minimum inlet air pressure is above 100 PSIG, typically you are able to reduce the size of the dryer. The reverse of this is also true. If your minimum pressure is below 100 PSIG, you must increase the size of the dryer. The sizing factor is a pressure ratio. You can size for pressure yourself using the following formula:

$$P1 = 114.7 / (P + 14.7)$$

Where: P1 = pressure modifier
P = minimum inlet air pressure

The inlet temperature is perhaps the most important factor when sizing the dryer. The air's capacity to hold moisture varies directly with its temperature. In the comfort zone of temperatures, a 20°F increase in temperature will nearly double the air's moisture holding capacity. This means that if you size a dryer for 80°F and the actual operating temperature turns out to be 100°F, you've doubled the amount of water going into the dryer.

When sizing either refrigerant or regenerative dryers, you must account for the air temperature with a temperature modifier. Many dryer companies use 100°F as their standard. If your inlet air temperature is above 100°F, then you must increase the size of the dryer to compensate for the increased water load. Conversely, if the maximum inlet air temperature is below 100°F, the dryer size may be commensurately reduced. See Table 2.

Max. Temperature	Multiplier
120°F	1.78
115	1.55
110	1.34
105	1.16
100	1.00
95	.86
90	.73
85	.63
80	.53
75	.45
70	.52
65	.44
60	.37

Table 2

The temperature does not affect the sizing of the deliquescent dryer; however, it does have a considerable impact on performance. Before we can dry the air, we must cool it in the aftercooler. The choice of coolers is nearly as important as the dryer, since you want to reduce the air temperature as much as possible. Also, if your compressor is lubricated, we will need to filter the oil and dirt out of the lines. Remember that the dryer is designed to remove water, not oil. If the oil is not filtered, it will reduce the efficiency of the dryer. Some filter salesmen try to sell their filters by saying they dry air. This is simply not true. A filter will remove liquid water that has already condensed, but it cannot remove any moisture vapor. A dryer by definition is a device which lowers the dewpoint of air. Filters are an essential component of the well designed compressed air system; however, they are not the solution to your wet air problems.

Let's assume that we want to dry 1000 SCFM at 100 PSIG and 100°F. Since temperature is not a factor in sizing deliquescent dryers, all we need to do is multiply the SCFM by our pressure modifiers; in this case, the modifier is 1.

DELIQUESCENT

The deliquescent dryer is the simplest and easiest dryer to own and operate and will be the best choice for many compressed air applications. The deliquescent dryer is a pressure vessel, which is filled with a hygroscopic desiccant. This desiccant deliquesces, that is, it draws water vapor out of the air and in so doing slowly dissolves. The dissolved desiccant and liquid water collect in the bottom of the tank where they can be easily drained. See Illustration 1.

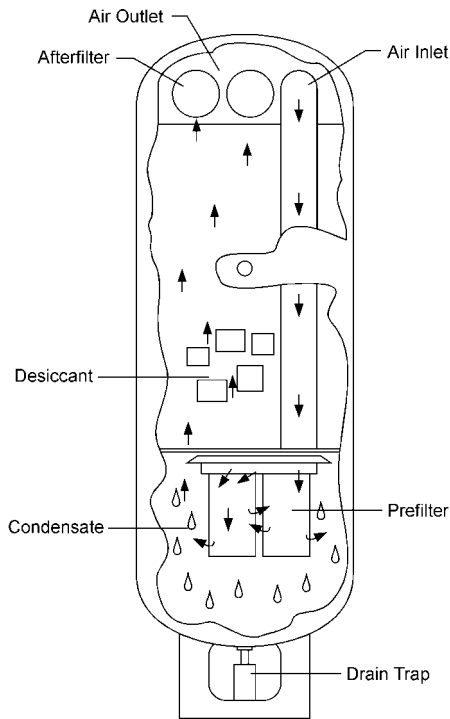

Illustration 1: Deliquescent Dryer Pressure Vessel

The performance of the deliquescent air dryer varies directly with the inlet air temperature. For outdoor air lines, we can make best use of the deliquescent dryer's varying performance by installing the dryer and an air cooled aftercooler outdoors. By using the varied ambient temperatures, the deliquescent dryer can deliver dewpoints below 0°F and has been protecting outdoor air lines from freeze-ups for many years. For indoor general shop air, we can use a water-cooled aftercooler upstream of the deliquescent dryer for good year round protection.

The only cost of operation for the deliquescent dryer is the replacement desiccant. Since the desiccant slowly dissolves while drying the air, you need to add more desiccant to the dryer every few months. The cost of the desiccant is inexpensive and because you only need add to the dryer as you use air, the overall cost of operation is the lowest of any type dryer.

There is no electricity used and the dryer has no moving parts.

There are, however, some drawbacks to the deliquescent dryer. If the temperature going into the dryer goes up due to a failure of the cooler, or whatever, the dryer will be overloaded and will be unable to perform.

The desiccant used in the dryer is an inert compound, based mostly on sodium chloride, although one manufacturer uses potassium carbonate. The desiccant by itself is generally not corrosive; however, because of its affinity for moisture and the presence of oxygen in the air stream, it is very easy for rust or oxidation to occur. It is very important that the dryer be adequately protected on the inside so that the vessel will not rust, and even more importantly, the dryer must be supplied with an afterfilter. It is quite common for deliquescent desiccant to carry-over into the air lines where it can cause considerable damage. The only way of preventing this is by installing an afterfilter either inside of the dryer, as shown in Illustration 1, or mounted downstream of the dryer. We would not recommend the use of deliquescent dryer without using an afterfilter.

REFRIGERANT

The refrigerant dryer reduces the dewpoint of the air, by reducing the temperature of the air, then separates out the condensed water. The refrigerant dryer is sized using both the pressure and temperature modifiers. Using our example of 1000 SCFM, 100 PSIG, 100°F, and the following formula, we determine the correct dryer size:

$$S1 = S \times P1 \times T1$$

S1 = modified flow rate

S = maximum inlet air in SCFM

P1 = pressure modifier

T1 = temperature modifier (from Table 2)

Thus, the refrigerant dryer should be sized for 1000 SCFM.

The refrigerant dryer is considerably more complex than the deliquescent and is, therefore, prone to mechanical failure. Wet air enters the refrigerant dryer through an air to air heat exchanger, where the temperature of the inlet air is reduced. This cooler air now goes into a freon to air heat exchanger where the temperature is reduced even further. At this point, the temperature of the air can be either +50°F or +35°F, depending on the dewpoint capabilities of the dryer. The moisture in the air has been condensed into liquid and is removed in a separator. The dry air now goes out of the dryer through the air to air heat exchanger where the temperature of the air is increased, typically to 70°F. See Illustration 2.

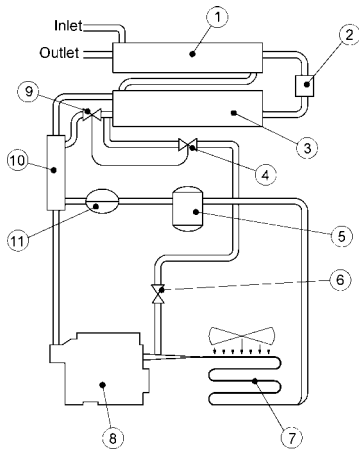

Illustration 2 Legend
 1. Air to air heat exchanger
 2. Separator
 3. Air to refrigerant heat exchanger
 4. Hot gas bypass valve
 5. Liquid receiving tank
 6. Hand shut-off valve
 7. Air-cooled condenser
 8. Refrigerant compressor
 9. Expansion valve
 10. Suction line heat exchanger
 11. Filter

Illustration 2: Refrigerant Dryer

On large refrigerant dryers, an air to water heat exchanger may be used instead of the air to air exchanger. The refrigerant dryer consumes electricity to operate the freon compressor and fans on the heat exchanger and also consumes water where a water to air exchanger is used.

Our example of a dryer rated for 1000 SCFM would typically have a 5 HP motor on the compressor and two 1/4 HP motors on the fans. If we assume that electricity costs .05/KWH, then the annual operating cost for this dryer used around the clock would be \$2,409.00 (5.5 KW x 8760 hours x .05/KWH).

There are a few drawbacks with the refrigerant dryer. It's common for a leak to develop in the freon system and once the freon leaks out of the dryer, it no longer functions. In addition, we have found that the actual performance is not as good as most manufacturers claim. The separators are not 100% efficient; they are, in fact, maybe 70-75% efficient, especially with varying flow rates, which means that the condensed water is not being removed, and is re-entrained back in the air stream. We have found that the actual dewpoints out of refrigerant dryer are approximately +40°F or +60°F.

If these dryers are delivering the specified dewpoints then they are acceptable; the problem is what happens if they don't perform up to spec. Then you may have very little margin for error.

Another problem is the choice of Freon. Several refrigerants have been banned and their replacements don't perform as well and are much more costly.

One of the biggest failures of refrigerant dryers is as simple as the drain trap. Drain traps don't work very well. Manufacturers constantly try to reduce cost to be more competitive. Where do they skimp? On the drain trap. If a chain is as strong as it's weakest link, then the poor drain trap is certainly the biggest problem with refrigerant dryers. If the trap doesn't

work, the entire dryer doesn't work. Water exits the dryer at only one place; the drain trap. If you don't see water coming out of the trap you might as well unplug the dryer.

Another limitation of this dryer is that the dewpoint cannot go below 32°F under any conditions, so that there is no way this dryer can prevent freeze-ups of outdoor lines. We would recommend the refrigerant dryer only be used indoors to protect against water getting in the plant air system.

While we have spent several pages discussing the operation and relative merits of the deliquescent and refrigerant dryer, the truth of the matter is that both of them are really obsolete. If all air lines are indoors and you don't have a specific application that requires lower dewpoints, then the performance of a deliquescent or refrigerant dryer should be acceptable. But what happens if the dewpoint goes up? Even a little bit?

Table 3 illustrates the amount of water present in compressed air at varying dewpoints, both in terms of gallons of water and percentage remaining.

Pressure Dewpoint	Water Remaining	
	%	Gal/Year.
100	100.00	24,786
80	53.39	13,234
60	26.98	6,687
40	12.81	3,175
35	10.52	2,608
0	1.95	483
-40	0.20	49
-100	0.002	1

Table 3: Moisture in Compressed Air; 1,000 SCFM, around the clock operation

As you can see, the dewpoint performance from both a deliquescent and refrigerant dryer still leaves a tremendous amount of water in the compressed air. The absolute lowest attainable dewpoint from a refrigerant dryer means that over 10% of the water stays in the air; with a typical 1,000 SCFM system, operating around the clock, this means that there is 2,608 gallons of water still present in the air. If the ambient never drops below 55 F then this should be acceptable, but what happens in you have a problem. If there's a Freon leak or, a trap gets plugged or, the dryer hiccups or you're having a bad hair day, the dewpoint can climb up. If it climbs up 25 degrees, up to 60°F, then you now have over 6,000 gallons of water flooding your air lines. Open a valve and your shoes get wet. Your instruments freeze, your tools rust. Production grinds to a halt.

There are different ways of looking at this situation. While we don't want to over-specify, we also don't want to get a phone call in the middle of the night because the plant is shut down. Even operating at peak efficiency, the refrigerant dryer puts more than 50 times more water in your air line than a regenerative dryer does. That really doesn't leave you any margin for error. Everything has to be perfect or you've got real problems. Perhaps the best solution is to use a dryer that gives you more; more breathing room, an opportunity to recover if there's a problem.

The ideal solution is to provide a dryer with a dewpoint low enough that if it hiccups you're still in operation. The solution is a regenerative dryer.

REGENERATIVE

Instruments, electronics, cryogenics, pharmaceuticals, flash freezing, and frozen outdoor air lines are all examples of why regenerative dryers are needed in industry. A regenerative dryer will deliver a dewpoint of -40°F and can go as low as -100°F at line pressure.

There are several different types of regenerative dryers, but they all conform to the same basic concept. A regenerative dryer consists of two pressure vessels, or towers, filled with a regenerable desiccant. This desiccant is like a sponge, in that it is able to soak up water; then after being squeezed or regenerated, it is once again able to soak up water. The desiccant in one tower is on-stream drying the air, while the desiccant in the other tower is off-stream being regenerated. The two towers are interlinked with switching valves, so that when the desiccant in the drying tower is saturated, the valves switch the flow into the tower that has just been regenerated. This all happens automatically, assuring you of the highest quality air all of the time. See Illustration 3.

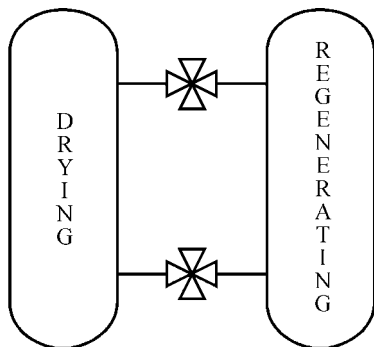

Illustration 3: Regenerative Dryer Pressure Vessels

Heatless

The basic difference between the types of regenerative dryers is the method of regeneration.

One of the most common types of regenerative dryers is the heatless or pressure swing dryer. This dryer is normally used for air flows below 1000 SCFM. This dryer has the lowest initial cost of any regenerative dryer. We size a heatless dryer the same way we did the deliquescent, multiplying the inlet flow rate by a pressure modifier to calculate the corrected dryer size. Temperature is not a factor when sizing a heatless dryer, as long as the inlet air temperature is below 120°F. If the temperature is above 120°F, the desiccant loses its efficiency, which results in higher dewpoints.

The heatless dryer utilizes the pressure swing principle to regenerate the desiccant bed. Wet air enters the dryer and is diverted into the drying tower where all of the air is dried to a -40°F dewpoint. At the outlet of the dryer, 15% of this dried air is diverted into the regenerating tower where it is expanded to atmospheric pressure. This super dry air now comes into equilibrium with the desiccant and draws the moisture off the desiccant, regenerating it back to full capacity. The wet purge air is then blown out to atmosphere. See Illustration 4. The valves switch every few minutes automatically diverting air from one tower to the other.

The heatless dryer is recommended for applications that don't use more than 1000 SCFM, or where electricity is not available. Because you are constantly losing 15% of your compressed air, the heatless dryer is the most expensive dryer to operate.

The Sahara T series heatless dryer is the simplest, most efficient heatless dryer available. Yet it still requires a 15% purge air loss. There are a variety of options available to try to reduce the average purge loss, however, when the dryer is faced with the worst case inlet conditions, when the dryer is operating at full capacity there is no purge savings. You're looking at a 15% air loss all of the time.

Industry calculates that compressed air costs .25/1000 cubic feet. This cost accounts for the initial price of the compressor, maintenance, power used by the compressor, and so on.

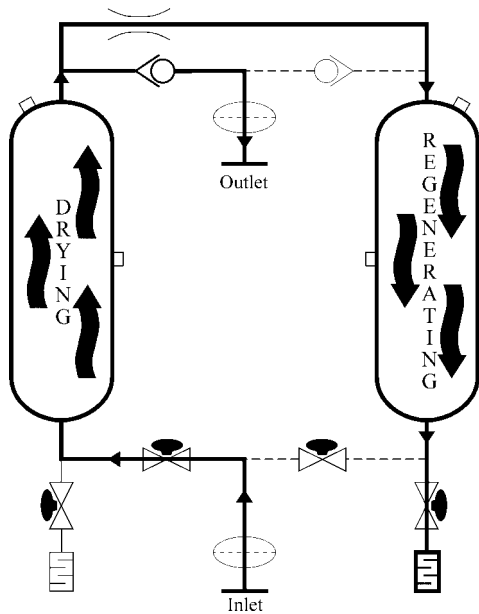

Illustration 4: Model T Series Heatless Flow Schematic

The heatless dryer sized for 1000 SCFM would have a continual purge air loss of 150 SCFM (15% of the inlet flow). To calculate the annual operating cost, we would use the following formula:

$$C = ([PR \times 525600] / 1000) \times S$$

Where: C = annual operating cost
 PR = purge rate in SCFM
 525600 = constant, minutes in a year
 1000 = constant, cost per 1000 cu. Ft.
 S = cost of compressed air, normally .25

The annual cost of purge air for the heatless dryer is \$19,710. The heatless dryer also consumes a small amount of electricity to operate the timer and solenoid valves; this is generally less than 50 watts.

Heat Reactivated

Because of the large purge loss of the heatless, many customers look at the heat reactivated type of regenerative dryers. These are the exhaust purge, blower purge, closed system, and the Sahara-Pak™ heat-of-compression.

Heat reactivated dryers regenerate by passing hot air over the saturated desiccant bed. Air has a varying capacity to hold moisture; the hotter the air is, the more water it can hold. So by heating the regeneration air, we are able to either reduce or eliminate completely the need for purge air loss. This is significant when dealing with large volumes of compressed air.

The sizing of a heat reactivated dryer is the same as a refrigerant; you multiply the flow rate by a pressure and temperature modifier to arrive at a corrected flow rate.

If you go back to Table 2 for just a second, take a look at the difference between an inlet temperature of 120°F, 100°F and 60°F. Big difference. Remember that the air's capacity to hold water doubles with every 20°F increase. Size a dryer for 100°F and give it 120°F and you need twice as much desiccant to hold that water. When designing a compressed air system, you must do everything possible to reduce the inlet air temperature entering the drying tower. Using chilled water has a tremendous impact on dewpoint performance, life of components, and initial cost; you save more money than you spend. Conversely, skimping on your cooling system and having hot water with a high approach aftercooler leads you down the road to ruin. The single most important factor in a drying system is the temperature of the air.

When sizing any regenerative dryer, there are several factors that should also be mentioned; velocity, contact time, desiccant capacity, and pressure drop. These items should be considered by the manufacturer. However, a prudent engineer should double check the manufacturer's figures to guarantee proper sizing of the dryer. This becomes particularly important if the pressure or temperature modifiers vary greatly from the standards. For example, if our inlet temperature was 60°F, we could reduce the size of the heat reactivated dryer by nearly 2/3, due to the reduced water load. However, the velocity through the bed would be too high and would fluidize the desiccant, the contact time would be too low to obtain a good dewpoint, and the pressure drop would be excessive.

You can calculate the flow velocity with the following formula:

$$V = (14.7 \times S) / (P + 14.7)A$$

Where: V = velocity in feet per minute
 S = inlet air flow in SCFM
 P = inlet air pressure
 A = tower area in sq. ft.

You can calculate the tower area, if you know the tower diameter with the following formula:

$$A = (TD^2 \times .785) / 144$$

Where: A = tower area in sq. ft.
 TD = tower diameter

A heat reactivated dryer rated for 1000 SCFM would typically have a 24 inch diameter tower. So, using our tower area formula, we arrive with a tower area of 3.14 sq. ft. We can now calculate the velocity to see if the desiccant will be fluidized. We see that the flow velocity would be 33.5 feet per minute. This is an acceptable flow velocity. Generally, velocity shall not exceed 60 feet per minute.

Most dryer manufacturers use 3/16 inch spherical activated alumina desiccant. Experience has shown this to be the best choice of regenerative desiccants. It has a dynamic design capacity of 24%; that is, it will hold 24% of its weight in water.

If the velocity of the air is high, it's a pretty sure bet that the contact time will be too low. The air must be in contact with the desiccant for at least 3 seconds in order for the desiccant to pull the water out of the air in sufficient quantity to give a good dewpoint. You can calculate the contact time with the following formula:

$$CT = [(P + 14.7) \times 60 \times AA] / (14.7 \times S \times 45)$$

Where: CT = contact time in seconds
 P = inlet pressure in PSIG
 AA = pounds of activated alumina per tower
 S = inlet air flow in SCFM

A heat reactivated dryer rated for 1000 SCFM would hold approximately 530 pounds of activated alumina per tower. The contact time would be 5.9 seconds; which is acceptable.

Most dryers are designed with a 3-5 pound pressure drop. You can calculate the approximate pressure drop using the following formula:

$$PD = ([S/M]^2 \times 344.1) / (P + 14.7)$$

Where: PD = pressure drop in PSIG
 S = inlet air flow in SCFM
 M = maximum air flow at 3 lb. Drop (see Table 4)
 P = inlet air pressure

The line size on a dryer rated for 1000 SCFM would be 3 inches. The pressure drop would be .96 PSIG.

By going through these calculations, you can guarantee that the dryer you purchase will be adequate for your current needs and will even handle future expansion.

Line Size (inches)	Flow Rate
1/4	11
1/2	45
3/4	80
1	150
1 1/2	400
2	700
3	1,600
4	3,000
6	7,000
8	12,000
10	18,000

Table 4: Maximum Flow of Air Through Dryer at 3 PSIG Drop

There are two basic methods of regenerating the desiccant with a heated dryer; they are convection and conduction.

A convection system heats a stream of air and allows the hot air to heat and regenerate the desiccant.

A conduction system typically has multiple heaters embedded throughout the desiccant bed and conducts heat through the desiccant. A small amount of air is required to pick up the moisture that is being regenerated off the desiccant.

There are several serious mechanical problems that can occur with strictly conduction heating. The desiccant itself is a very poor conductor of heat. In order to distribute heat throughout the desiccant bed, you generate very high temperatures right at the heater. This drastically reduces desiccant life. Heater tubes expand and contract and can crush desiccant, the tubes can break and hot spots develop on the heater element. Typically this design has very high discharge temperatures at tower shift as well as elevated dewpoints. A much better approach is convection; using the heater to increase the temperature of the air and then allowing the hot air to regenerate the desiccant.

Heat reactivated dryers operate on a much longer time cycle than heatless dryers do. Typically, the heated dryer uses an 8 hour cycle, versus a 4 or 8 minute cycle for the heatless. This is necessary because of the time involved in heating and cooling the desiccant during regeneration.

Exhaust Purge

The exhaust purge dryers are similar to the heatless in that there is a purge air loss; however, because we are heating the purge air and desiccant, we can reduce the purge air to 7% of the dryer flow rate. By reducing the purge loss by half, we greatly reduce the operating cost of the dryer. See Illustration 5.

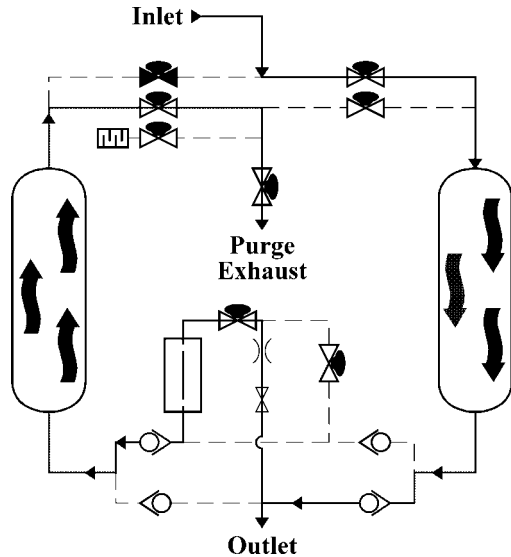

Illustration 5: Exhaust Purge Flow Schematic

Wet air enters the dryer and is diverted into the drying tower where it is dried to its -40°F dewpoint. At the outlet of the dryer, 7% of this dried air is diverted into the regenerating tower where it is heated and expanded to atmospheric pressure. This hot dry air comes into equilibrium with the desiccant and regenerates it back to full capacity. The wet air is then exhausted to atmosphere. We heat the desiccant for 3 hours to fully regenerate it, then turn off the heater for the last hour prior to tower shift to cool the bed down. The reason for this is that the desiccant is not effective if its temperature is above 140°F. So we cool the bed down with cool, dry air. This minimizes any temperature or dewpoint spikes at tower shift.

The operating cost of the exhaust purge dryer is determined by the purge air loss and the electricity used by the heaters. You can calculate your purge loss by multiplying the modified flow rate (1000) by .07 to arrive at a purge loss of 70 SCFM.

An exhaust purge dryer rated for 1000 SCFM would typically have a 12 KW heater. The heaters used are normally incoloy sheathed and derated to 14 watts per square inch. These heaters are capable of our 1000°F; however, we only need heat the purge air to 375°F to assure good regeneration. Usually, there will be some excess capacity in the heater KW, and this can be calculated using the following formula:

$$KW = (PR \times 1.08 \times TD) / 3412$$

Where: KW = actual KW required
 PR = purge rate in SCFM
 TD = temperature differential between 375°F and inlet air temperature

We see that we only need 6 KW to heat 70 SCFM from 100°F to 375°F. We can now calculate the operating cost of the dryer with the following formula:

$$C = ([PR \times 525600] / 1000) \times CA + (KW \times 6570 \times E)$$

Where: C = annual cost
 PR = purge rate in SCFM
 CA = cost of compressed air per 1000 cu. ft.
 KW = actual KW required
 E = cost of electricity

The total cost to operate the exhaust purge dryer for one year is \$11,169, using .05/kw for electricity.

Blower Purge

The blower purge is another type of heat reactivated dryer. This dryer is used when you do not want to lose any compressed air. Regeneration is accomplished by blowing ambient air into a heater, heating the air to 375°F, then passing this hot air into the regenerating tower. Because there is no purge air loss, the blower purge dryer is used to dry large volumes of compressed air. See Illustration 6.

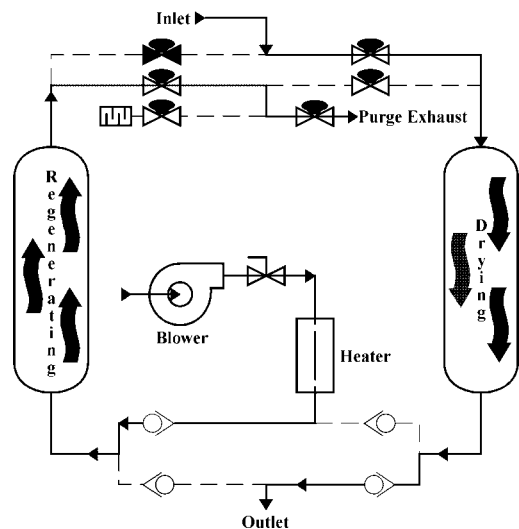

Illustration 6: Blower Purge Flow Schematic

The Blower Purge dryer also operates on an 8 hour time cycle; 4 hours of drying, 3 hours of heating and 1 hour of cooling. Normally an electric heater is used, however, if waste steam is available then this is usually more energy efficient. A source of 125 PSIG steam is the minimum requirement. When a steam heat exchanger is selected, it is important to bypass the heater during cooling. Simply shutting off the steam flow results in shortened life of the exchanger.

The Sahara Blower Purge dryer design incorporates a very unique feature to provide constant low dewpoints. Conventional Blower Purge dryers use the ambient air blower during both heating and cooling. Unfortunately, if the dryer is located in a hot, humid environment, during cooling the moisture present in the ambient air is deposited on the bottom of the desiccant bed. When the dryer shifts towers and that bed is used for drying, the moisture on the bottom of the bed is picked up by the air; thus there may be a fairly substantial dewpoint spike at tower shift. To prevent this, Sahara provides a selector switch on the control panel, allowing each user to choose either blower cooling or exhaust cooling. If exhaust cooling is selected then the blower and heater are both turned off after 3 hours of heating. A small (5%) purge of dry air then enters the regenerating tower and cools the desiccant bed. This exhaust cooling has the additional benefit of providing lower dewpoints than conventional blower cooling.

The operating cost of the blower purge dryer is determined by the blower HP and the heater KW. A blower purge dryer rated for 1000 SCFM would have a 3 HP blower and a 24 KW heater. The blower motor would consume approximately 3 KW and generate 180 SCFM at 32 oz. Of pressure. We can calculate the actual heater requirement for the blower purge just as we did for the exhaust purge. We see that the actual requirement is 15.6 KW.

The annual operating cost can be determined with the following:

$$C = (HP \times 8760 + KW \times 6570) \times E$$

Where: C = annual cost
 HP = blower horsepower
 KW = calculated heater KW
 E = cost of electricity

The annual operating cost of the blower purge dryer is \$6,438.60, based on .05/kw for electricity.

Closed System

The closed system dryer is typically used for gases other than air or when extremely low dewpoints are required. See Illustration 7.

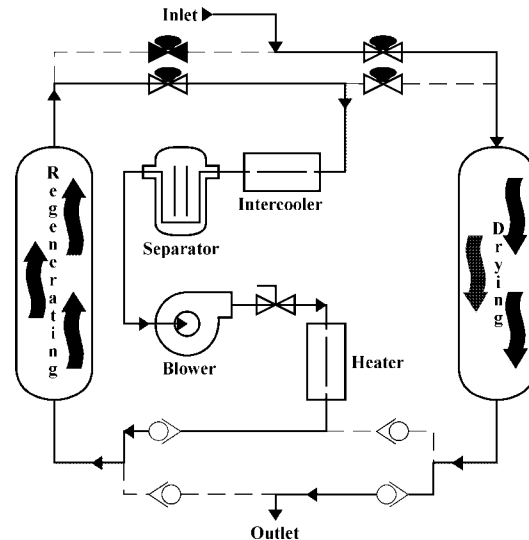

Illustration 7: Closed System Flow Schematic

Closed System dryers are usually considered specialty dryers. Process gas is not vented to atmosphere nor is it contaminated with ambient air. This dryer is a good choice for drying natural gas or other product gases. The Closed System dryer regenerates by recirculating a captive volume of gas through a blower, heater, the regenerating tower and a heat exchanger. Given the right operating conditions, the Closed System dryer is capable of producing constant dewpoint of -100°F or lower.

There are several things to look for when specifying a closed system dryer. The most important item is the method used to separate the regeneration and process air flows. You can use either a booster blower and increase the pressure of the regeneration air or a differential pressure valve and drop the pressure of the process gas. We recommend the booster blower for several reasons. First, with a differential pressure valve, you are reducing the pressure of your air by 2-3 PSI. Any pressure drop is expensive; purposely dropping your line pressure is just plain foolish. Second, the valve and controller are very sensitive instruments which are prone to mechanical failure. One of two things can happen. Either the valve opens more, causing an even higher pressure drop, or it closes, which reduces the regeneration system and does not regenerate the dryer. Either way, the dryer is not working as it should.

The operating cost of the closed system is determined by the HP of the booster blower, heater KW, and GPM of cooling water. The blower on this size dryer would be 3 HP. The heater is 24 KW; however, we don't use all of the heater capacity.

The actual KW requirement is 19.4 KW. The cooler has to cool 200 SCFM down from 375°F to 100°F. It will require 3.3 GPM of 85°F water to accomplish this. Our power requirements are: blower 1 KW, heater 19.4 KW, cooler 3.3 GPM. The annual operating cost will be \$8,545.38.

$$C = ([HP \times 8760] + [KW \times 6570]) \times E + ([GPM \times 525600] / 1000) \times WC$$

Where: C = annual operating cost
 HP = blower KW
 KW = heater KW
 E = cost of electricity
 GPM = water rate
 WC = water cost/thousand gallons (typically \$1/1000 gallons)

Heat-of-Compression

All of the dryers we've discussed so far share one common denominator; they all are designed to operate downstream of the aftercooler. But what's happening back at the compressor? Is the air exiting the compressor saturated? The answer is no; remember the varying capacity of air to hold water at elevated temperatures. Air exiting a compressor is definitely not saturated and can in fact hold a tremendous amount of water. All of the conventional dryer designs were built to operate at the conditions following the aftercooler. Back in the 1970's, Sahara started manufacturing compressor/dryer packages. It became obvious that a good potential source of energy was being wasted.

Heat is energy. During the compression process heat is essentially a by-product of compression. Air exiting a compressor is hot. Because of the high temperature the air isn't wet. When this hot, dry air is put into an aftercooler, all of the energy is wasted. With a regenerative dryer, a new source of energy must be provided to regenerate the desiccant.

Back in the 70's, Sahara developed and patented the Heat-of-Compression dryer design. We called it the Sahara-Pak, because it was a complete package; an aftercooler and dryer, specifically designed to function at peak efficiency.

By utilizing the normally wasted heat-of-compression to regenerate, the Sahara-Pak does not lose any compressed air and requires no electricity for either heaters or blowers. The only power required is approximately 27 watts which operates the timer and solenoid valves. See Illustration 8.

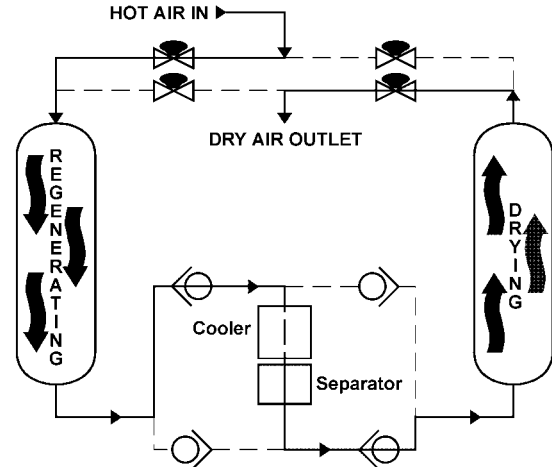

Illustration 8: Heat-of-Compression Flow Schematic

Air enters the Sahara-Pak directly from the compressor. This hot, thirsty air is directed into the regenerating tower, where it removes the moisture from the desiccant bed. This cooler, wetter air now enters an aftercooler where it is cooled down to approximately 100°F. Moisture is condensed and removed in a coalescing separator with a dual drain trap. All the liquid water is removed through the drain traps. By using two separate traps, a mechanical and electrical trap, we are assured of continual draining. If the primary mechanical trap should fail, the liquid backs up into the electrical trap where it will be drained. Should the backup electric trap ever have to work, it will signal a primary drain failure alarm light and horn on the dryer control panel.

Now that the liquid has been separated and drained, we can dry the air. The air now goes into the drying tower where it reaches its final dewpoint. At a preset interval, the valves shift, diverting air into the opposite tower. The Sahara-Pak is one of the simplest, most trouble-free type of dryers to operate, and because of its energy-saving design, has become extremely popular. The major limitation of this dryer is that it must be located near the compressor and is, therefore, not suitable for point of use applications. Also, the compressor must be oil-free.

The outlet dewpoint is determined by three factors; ambient dewpoint, inlet air temperature, and cooling water temperature. The hotter the air is going into the dryer, the lower the dewpoint will be going out. The dewpoint is also affected by the temperature of the air exiting the cooler. Here we want it to be as cold as possible.

One other factor with the Sahara-Pak, just like other heated dryers, is temperature and dewpoint bump. This occurs right at the dryer, so we recommend installing a dry air receiver downstream of the dryer to allow the air a chance to mix, to assure a low dewpoint all of the time.

The Sahara Pak SP design is considered to be an instrument air dryer in that it delivers air in accordance with the requirements of the Instrument Society of America. While most customers can accept temporary dewpoint excursions, some process applications require a constant low dewpoint. For these applications Sahara developed the HC design.

The HC dryer operates through 3 separate cycles; heating, stripping and cooling. Illustration 9 shows the heating cycle. The heating cycle of the HC dryer is identical to the cycle of the SP; all of the hot air from the compressor enters the regenerating tower and regenerates the desiccant. From there it enters the aftercooler where it is cooled to as low as possible, at least 100°F. Condensed moisture is removed in the separator and drain traps. The cool wet air flows up through the drying tower where it is dried. The heating cycle lasts for 90 minutes.

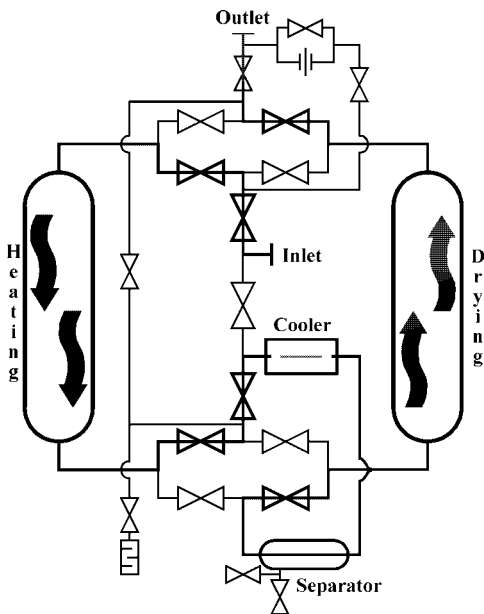

Illustration 9: Heat-of-Compression Heating Cycle

At the end of heating the HC design enters the stripping cycle. See Illustration 10. During stripping, the hot air from the compressor is directed into the aftercooler, separator, and drying tower. A small amount of dry purge air (5%) is expanded to atmospheric pressure and is used to purge the regenerating tower. Stripping lasts for 90 minutes. The amount of purge is small, only 5% and only lasts for 90 minutes every 4 hours, or longer if the dryer is equipped with the dewpoint demand system. The cost of the purge air is negligible when compared to other types of dryers. An additional benefit of the stripping flow is enhanced regeneration. The HC is actually capable of delivering dewpoints 30°F lower than the SP design.

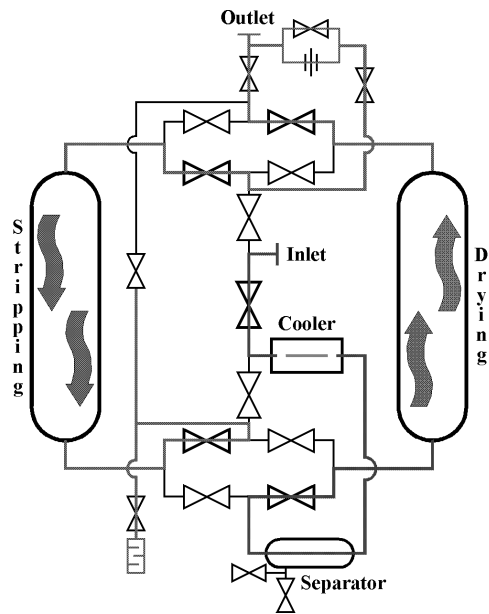

Illustration 10: Heat-of-Compression Stripping Cycle

After stripping, the HC dryer enters the cooling cycle. See Illustration 11. During cooling, the hot air from the compressor enters the aftercooler, separator, and drying tower. At the outlet of the dryer, about 25% of the dry air is directed into the regenerating tower to cool the desiccant bed. This cooling air flow rejoins the process flow at the outlet of the dryer, so there is no air lost during cooling. After 60 minutes of cooling the dryer is ready to shift towers. Usually all regenerative dryers are purchased with the optional dewpoint demand system. This is a direct reading dewpoint meter that optimizes the energy consumption of the dryer and switches towers based on outlet dewpoint rather than time. The dryer should remain on the drying tower for hours waiting for the dewpoint to increase.

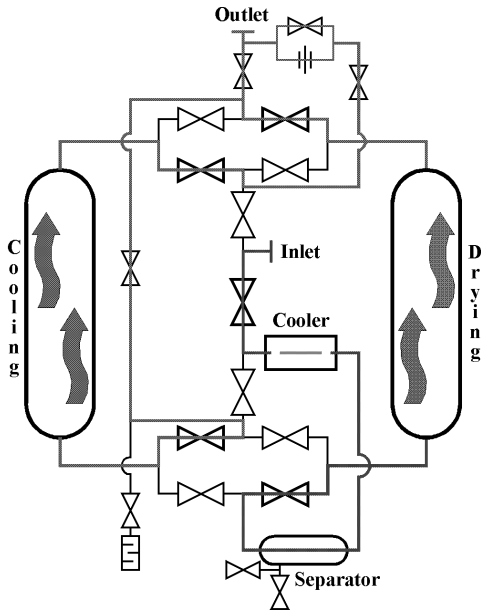

Illustration 11: Heat-of-Compression Cooling Cycle

Table 5 shows a cost comparison of regenerative dryers. Note that all dryers require a small amount of electricity to operate the timer and solenoids.

Dryer	Purge Air	Heater	Blower	Cooler	Cost / 1000 SCFM / 1 year
Heatless	15%	No	No	No	\$19,710.00
Exhaust Purge	7%	Yes	No	No	11,169.00
Blower Purge	No	Yes	Yes	No	6,438.60
Closed System	No	Yes	Yes	Yes	8,545.38
Heat-of-Compression - SP	No	No	No	No	0
Heat-of-Compression - HC	2% Avg.	No	No	No	657.00

Table 5: Cost comparison of Regenerative Dryers. (Does not include replacing desiccant.)

Dryer	Initial Cost	Energy Cost	Maintenance Cost	1 Year	5 Years
Deliquescent	\$ 4,400.00	\$ 0	\$ 705.00	\$ 5,105.00	\$ 7,925.00
Refrigerant	12,000.00	2,409.00	100.00	14,509.00	24,545.00
Heatless	10,428.00	19,710.00	396.00	30,534.00	110,958.00
Exhaust Purge	18,779.00	11,169.00	879.00	30,827.00	79,019.00
Blower Purge	28,072.00	6,438.60	879.00	35,389.60	64,660.00
Closed System	33,686.00	8,545.38	879.00	43,110.38	80,807.00
Heat-of-Compression - SP	20,240.00	0	585.00	20,836.81	23,224.00
Heat-of-Compression - HC	28,125.00	657.00	879.00	29,661.00	35,805.00

Table 6: Comparison of all dryers.

Since this is the same for all, we cancelled it out. In reality, this costs less than \$10/year.

Table 6 shows a comparison of all dryers with a rough estimate of today's initial cost and a one year and five year comparison of energy costs. We have also estimated the cost to maintain the refrigerant dryer which consists mainly of replacing freon, and have also estimated the cost to replace desiccant in the regenerative dryers. We have not added in any factor for increasing energy costs. To do this would be guessing at an inflation rate which is something we do not look forward to. Unfortunately, the cost of energy has been skyrocketing lately. The only thing I can safely say is that the cost of electricity will be more next year than it is now. Both the deliquescent dryer and Sahara-Pak dryer do not use energy, so they will not be affected by rising energy costs.

In conclusion, we believe that while any dryer will improve plant production enough to pay for itself many times over, it is the job of both the dryer manufacturer and the plant engineer to select not only the dryer that will deliver adequate dewpoints and assure dry air, but also have the lowest operating cost.



SAHARA AIR PRODUCTS
 A Division of HENDERSON ENGINEERING COMPANY, INC.
 95 North Main Street • Sandwich IL 60548
 815-786-9471 • 800-544-4379 • Fax: 815-786-6117
www.saharahenderson.com